

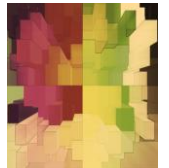

OCTEVAW - COCVFF

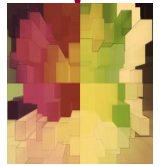

OCTEVAW

Annual General Report

2016

601-250 City Centre Ave
Ottawa, ON, K1R 6K7
octevaw-cocvff.ca
613-237-1000

TABLE OF CONTENTS.

Mission, Vision & Values	1
Coalition Structure	2
Board of Directors' Report	3-4
Executive Director Report	5
Staffing	6
Student Interns & Volunteers	7
Thank you Funders!	8
<i>Partnerships</i>	9
<i>Membership</i>	10-11
<i>Standing Committee: Front Line Support</i>	12-15
<i>Standing Committee: Public Engagement</i>	16-17
<i>Standing Committee: Justice</i>	18-19
OCTEVAW & Social Media	20
Financial Report	21-23

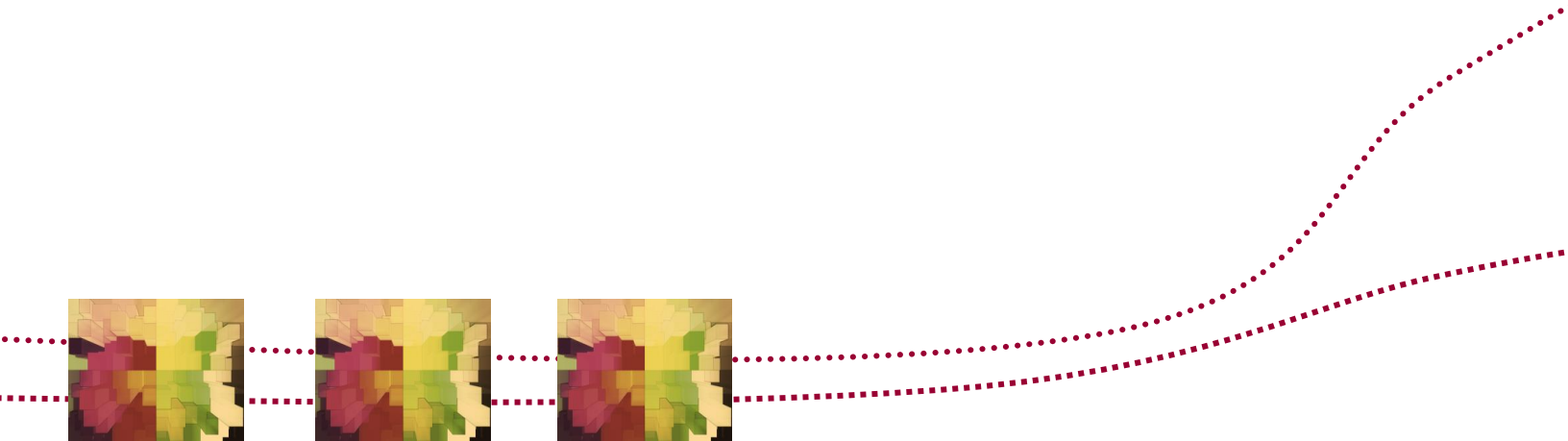



MISSION.

OCTEVAW unites organizations and individuals in Ottawa and the surrounding region to end gender-based violence and abuse, including violence and abuse against women and children.

VISION.

OCTEVAW aspires to a future in which:

- All members of the community, including individuals, organizations, policy makers, and the legal system are united in efforts to ensure a permanent end to all gender-based violence, including violence and abuse against women and children.
- Respect for the inherent worth and dignity of women, trans and gender-variant individuals is reflected in our public institutions.
- Women, trans and gender-variant individuals are able to live violence-free lives rooted in autonomy and self-determination.

VALUES.

OCTEVAW works collaboratively with members and stakeholders in accordance with feminist, anti-oppressive, anti-racist, and pro-choice principles. We recognize the intersectionality and interlocking of oppressions and seek to address these realities in our work. We are committed to the struggle for social justice for all individuals who are marginalized and oppressed, and to advancing the cause of decolonization, reproductive rights, and disability, queer and trans justice.

COALITION STRUCTURE.

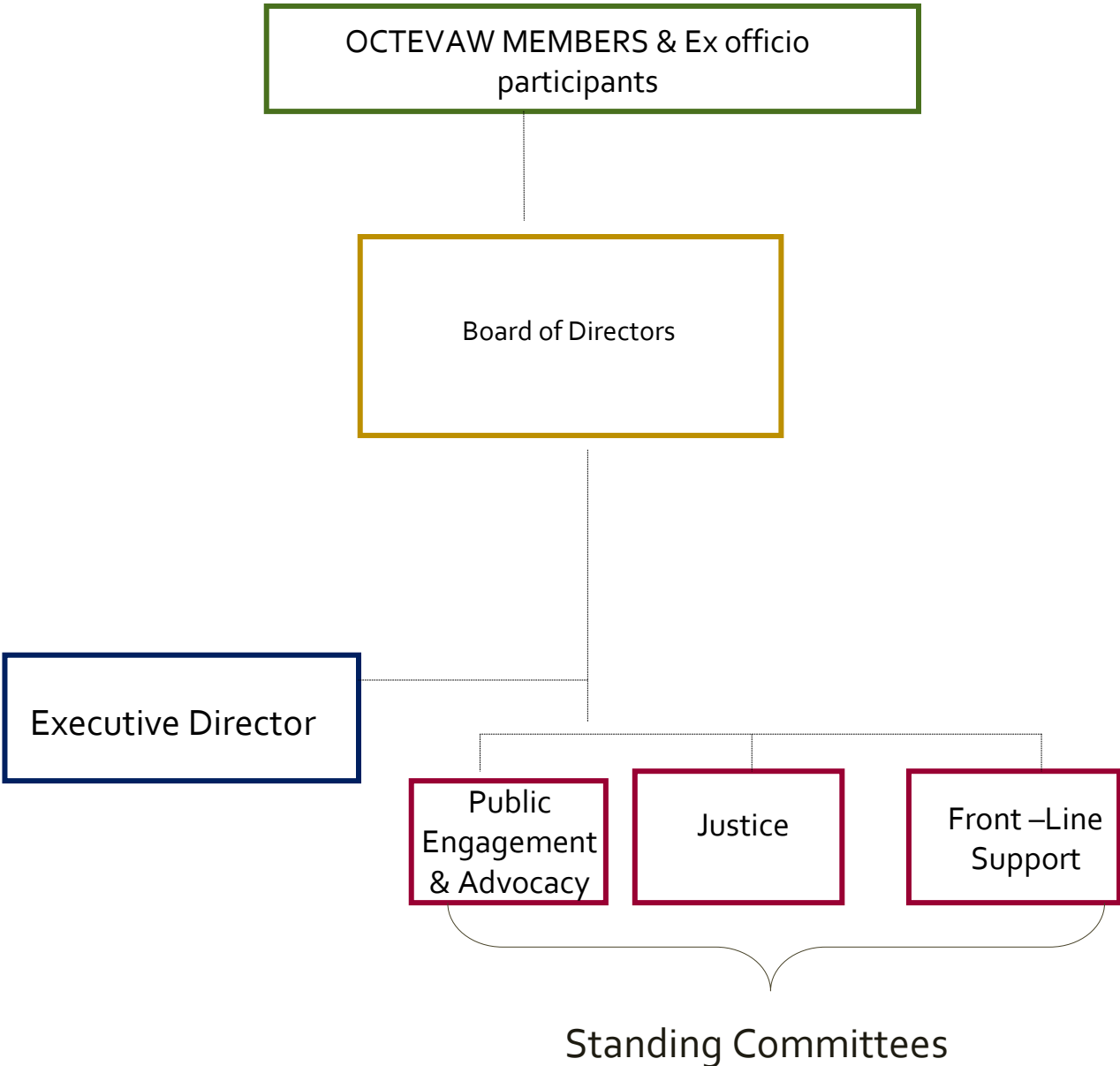

Board of Directors' Report.

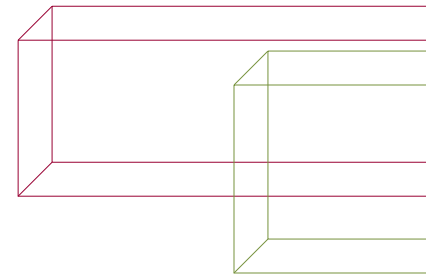

As Chair, I want to personally thank our Board of Directors for their creativity, patience and dedication over the last year. We have completed a lot of work resulting in an amended mission statement, vision and values. We have also re-focused our program areas and restructured our Board of Directors model.

We have been working on transitioning our Board infrastructure and overall program goals and objectives since September 2015. The strategic priorities answer “where are we going?” and “how will we know when we get there?” Ensure that outcomes are SMART - Specific, Measurable, Achievable, Realistic, Timely – which allows the organization to adapt and change course when goals are not being met, and consolidate gains and set new goals when we reach our objectives.

A full review of the vision, mission statement, values has been completed, as you can see on page 1 of the annual report. Our analysis has resulted in the agreement that we needed to change our mission, vision and values to keep pace with the changing environment, and that our priorities support these updates. I want to thank the membership for engaging in discussions at committees and online on these changes, and providing your leadership and support to this process.

In reviewing our programming, the Board has shifted its focus away from the program categories captured in our last Strategic Plan which were: Prevention; Systems Change; Coalition Building and Coordinated Response, and Support for Women. The following program priorities reflect the work we have been doing in a clearer framework that is more streamlined with our day to day activities:

- Prevention of Violence Against Women and Gender-Based Violence
- Public Education and Movement Building
- Amplifying Front Line Voices

We have also moved away from the original “member at large” board model to a model comprised of portfolios, led by Directors.

These portfolios are:

- | | |
|--|----------------|
| 1. Chair | 1 position |
| 2. Chair Elect | 1 position |
| 3. Immediate Past Chair | 1 position |
| 4. Finance and Treasurer | 1 Director |
| 5. Human Resources | 1 Director |
| 6. Revenue Generation | 2 Co-Directors |
| 7. Communications | 2 Co-Directors |
| 8. Governance and Succession Planning | 1 Director |
| 9. Membership and Stakeholder Engagement | 2 Co-Directors |



These positions and their portfolios will ensure that Erin has the support that she needs, that Directors are held accountable to their portfolios and resulting deliverables to ensure the continued success of OCTEVAW.

The Board of Directors would like to recognize the hard work of the Chairs of the Standing Committees:

- ✓ Front Line Support: Adriana Oatu as Coordinator
- ✓ Justice: Peter Jupp and Diane George
- ✓ Public Engagement: Bailey Reid and Valerie Colicott
 - and special thanks to Geneviève Charest for chairing the Shine the Light sub-committee

As a Board we will continue to do our best to serve our membership and move forward in implementing our action plans to move OCTEVAW forward.

ELECTED DIRECTORS AS OF APRIL 2016

- Marie-Louise Doyle (Chair)
- Rosario Castro
- Sylvie Charbonneau
- Mandy Faulkner
- Kellie Fong (Treasurer)
- Peter Jupp
- Humaira Kadri
- Abigail Kidd
- Barbara Laskin
- Laure Prevost
- Bonnie Stephanson

DIRECTORS WHO ENDED THEIR TERMS

- Rosario Castro
- Mandy Faulkner
- Ubah Hersi
- Bonnie Stephanson

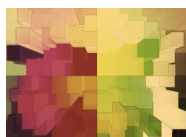



EXECUTIVE DIRECTOR'S REPORT.

2016 has been another year full of movement on violence against women. We see the tides turning in the public discourse, and are working tirelessly for this to lead to real change and an end to violence against women and gender based-violence.

Our three committees continue to inspire me - front-line workers showing incredible care and insight into the lives of women experiencing violence. The committees consistently identify on the ground barriers and opportunities that are present to help shift the public narrative and effect systemic change.

Both the Front Line Support Committee and Justice Committee led in supporting the OCTEVAW-led research project on Mandatory Charging. Deborah Conners, PhD and Prof. Holly Johnson are leading the academic survey collection of women's perceptions of mandatory charging. Our committees dedicated valuable time to contribute their expertise to support the project to be nuanced and reflective of the complex realities women face.

The Public Engagement Committee continues to build events and outreach that connect with many in Ottawa, many are amongst our target age group of young women and men, who are at greater risk of violence. For example, the committee developed OCTEVAW's very own game 'Cards Against Misogyny'!

On the prevention programming realm of our work, Dillon Black has worked closely with Purple Sisters Youth Advisory Committee at the YSB to create the wonderful techwithoutviolence.ca. This website gives tips to young people about how to navigate the murky waters of social media, but more importantly, it sets out recommendations to the companies that run them, and challenges them to take a proactive stance to ending gender-based violence online.

MANifest Change has continued to have a strong presence in Ottawa, delivering workshops with young men in high schools and beyond. We have provided training to local professional and varsity athletes, a key target group for this work. We also received generous support from Crime Prevention Ottawa in autumn 2016, and this will go into 2017 to support agencies working with youth in conflict with the law. The youth justice sector has enthusiastically engaged in supporting the young men they work with to help prevent VAW.

It is also with great sadness that we have lost amazing members of the OCTEVAW community including Annette Werk who was a past chair of the Justice Committee and continued to represent JFS with passion and intellect, and the formidable Lucya Spencer, the ED of the IWSO. These luminaries will be missed in Ottawa and beyond.

It is our responsibility to these leaders to continue to strive to achieve more great things in 2017. I am in constant awe of the passion, dedication and expertise that our front line agencies bring to bear in our work, and across the city. Thank you.

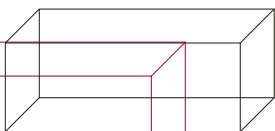



STAFF. OCTEVAW continues to have one (1) paid full time staff (35 hours a week), which is the Executive Director. Her position is both funded by the City of Ottawa (4 days) and the Ministry of Community and Social Services (1 day).

CONTRACT STAFF.

The OCTEVAW contract staff is as follows:

- **Dillon Black**- Cyberviolence project
- **Matt Schaaf** – I Can MANifest Change
- **Sonia Figuracion** – Bookkeeper
- **Annelies Van Oers**-Web Administrator
- **Wolfworks** printing

We are so lucky to have such dedicated individuals with insight, intellect and passion for the work of OCTEVAW and its members.

VOLUNTEERS.

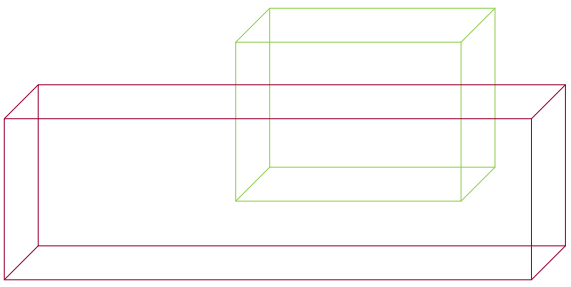

OCTEVAW relies on the intelligence and dedication of volunteers to underpin its programming. Our CourtWatch Program, MANifest Change and Cyberviolence projects would not have the leadership necessary without volunteers. Many thanks for contributing so fundamentally to our work.

Court Watch Coordinators

Helena Beeker, Sherley Merise,
Kevin Putinski

Court Watch Volunteers

- | | |
|----------------------|------------------------|
| Alydyl | Krysta Mclsaac |
| Arienne Carew | Natasha Szach |
| Baveeta Uthayakumar | Rachel Georgina Gopaul |
| Brianna Garneau | Rita Sarker |
| Caroline Hards | Sarah Mack |
| Emma Loader-Ricci | Savannah Gentile |
| Emma Skowron | Sukhman Grewal |
| Farah Zaman | Thelma Essibrah |
| Ferne Leigh | |
| Genevieve Boulay | |
| Joanna Chan | |
| Kathryn McKinleyanna | |
| Katrina Baumeister | |

Placement Students

- Silya Shenassa, Algonquin, SSW
 Alison Towns, Ottawa U, Law School Fellow
 Megan Patterson, American International University, Hungary
 Suzie Dunn, U Ottawa Masters of Law internship
 Kate Forman, Carleton, BSW

YSB Purple Sisters Cyberviolence Project

- | | |
|-----------|--------|
| Athourina | Tam |
| Holly | Amira |
| Lyra | Kayla |
| Munea | Violet |
| Rayanne | |

MANifest Change

Community Facilitators

- Clayton Dignard
 Benjamin Miller
 Phil Mineau
 Omar Mahfoudhi
 Chris Tremblay
 Reed Beall
 Sabastien Callendar
 Aaron Stevens
 Jan van Heusen
 Brent Lamborn
 Peter Farrell
 Greg White
 Greg Laforce
 David Veshkini
 Tyler Blanchett
 Ali Beshir
 Sharmaarke Abdullahi
 Brandon Rouleau

Advisory Committee

- Ali Beshir
 Beck Hood
 Aaron Leach
 Sharmaarke Abdullahi
 Clayton Dignard
 Omar Mahfoudhi

With support from

- Kira-Lynn Ferderber

THANK YOU FUNDERS!

Our funders demonstrate wisdom and confidence in supporting the Coalition. Without the generous support of our funders, the important work of enhancing a coordinated response to violence against women, and prevention programming to ultimately end violence would not be possible. Thank you!



Status of Women Condition féminine
Canada Canada



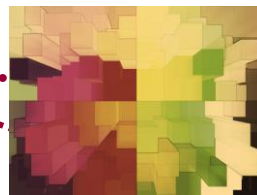

PARTNERSHIPS.

In 2016 OCTEVAW began or continued to contribute to and/or support the following agencies, projects or committees:

eQuality
project

City for All Women
Initiative (CAWI)

Provincial
Domestic Violence
Community
Coordinating
Committee

Planned Parenthood
Ottawa
VAW & SRH

Committee on
Disability and Abuse
(CODA)

Sexual Assault
Network Advisory
Committee

Women's
Event
Network

International
Women's Day
Pan-
Organizational
Committee

In Love and In Danger
Family Services
Ottawa

Domestic Violence
Court Advisory
Committee

OCTEVAW MEMBERSHIP.

VOTING MEMBER AGENCIES (2016)

Amethyst Women's Addiction Centre
Canadian Centre for Gender and Sexual Diversity
Canadian Resource Centre for Victims of Crime
Carleton University- Equity Services
Carleton University -Department of Safety
Carlington Community Health Center
Catholic Family Services
Comité Réseau d'Ottawa
Dress for Success
Eastern Ottawa Resource Centre
Family Services Ottawa
Families of Sisters in Spirit
HURT Association
Interval House of Ottawa
Immigrant Women Services Ottawa
Jewish Family Services-Shalom Bayit
Maison d'Amitié
Nelson House of Ottawa Carleton
Ottawa Victim Services
Ottawa Rape Crisis Centre
Pinecrest-Queensway Community Health Centre
Planned Parenthood Ottawa
Rae of Light
Safe Pet Ottawa
Sexual Assault Network
Somerset West Community Health Centre
University of Ottawa – Department of Criminology
University of Ottawa Legal Clinic
Western Ottawa Community Resource Centre
Women's Initiatives for Safer Environments (WISE)

OCTEVAW CURRENTLY HAS 13 VOTING COMMUNITY MEMBERS.

Halina Siedlikowski
Holly Johnson
Joan Gullen
Lynne Oreck-Wener
Toby Brooks
Khoa Hoang
Bailey Reid
Jordan Fairbairn
Marie-Louise Doyle
Jamie Liew
Kathryn McKinley
Sarah Jones
Genevieve Charest

NON-VOTING MEMBER AGENCIES (2015)

City of Ottawa-Ottawa Public Health
City of Ottawa – Social Services Department
Crime Prevention Ottawa
Crown Attorney's Office
Ministry of Community Safety and Correctional Services-Probation and Parole
Ottawa Community Housing
Ottawa Hospital, Partner Abuse and Sexual Assault Care Program
Ottawa Police Services, Partner Assault Unit
Ottawa Police Services, Sexual Assault and Child Abuse Unit
Ottawa Police Services, Victim Crisis Unit
Victim Witness Assistance Program



REPORT FROM STANDING COMMITTEES.

Frontline Support Committee

FLSC meetings are held from September to June every 6 weeks at Family Services Ottawa. There were 7 meetings held in 2016.

Our work plan continues to have the following goals:

- Provide a forum for networking, sharing information and providing support
- Identify trends / issues within VAW field
- Optimize options for women seeking service re: abuse
- Maintain a grassroots perspective of service delivery
- Engage in political action and advocacy
- Promote public awareness regarding VAW
- Support and promote diversity and accessibility
- Acknowledge workplace safety and emotional well-being

In the past year, the FSLC engaged in the following:

Ottawa Police Service (OPS) VAW Advisory Project – representatives from the FLSC participate in this project advocating for changes to OPS practices that will improve response for women experiencing violence.

Building a Bigger Wave – OCTEVAW’s Executive Director attends the provincial committee that continues to work on the mandatory charging project. The goal is to bring forward women’s voices and address inconsistencies in policy and practice. The FLSC contributed to the development and dissemination of the surveys for women and service providers (see Justice Committee report).

OCTEVAW “Have You Been Assaulted” Pamphlets : FLSC members reviewed and updated these pamphlets that are distributed across the city for women to have access to information and resources if they are experiencing partner violence.

Intake Worker Presentation. Following discussion about the importance of supporting intake workers at community health and resource centres to respond to disclosures of violence, Erin Leigh and Marie Louise Boudreau gave a VAW presentation to intake workers.

The following guest speakers contributed their expertise at the FLSC meetings:

- Elsy David, Program Director from the Women’s Initiatives for Safer Environments (W.I.S.E.) presented on how FLSC could consider conducting safety audits in emergency shelters.
- Donna Watson Elliot , Victim Crisis Unit, OPS, - provided updates on new changes in providing services by VCU to survivors of VAW.
- Marie France Theriault, Family Law Mediator - Family Law Mediation with Legal Aid Ottawa: gave a presentation on providing an option for families outside the court process.
- Deborah Conners, lead for BBW Mandatory Charging project.- Discussion and reviewed draft survey for Mandatory charging impact research project.
- Holly Johnson presented her research launched in November 2015 on survivors experience when contacting the Ottawa Police service: Improving police response to crimes of violence against women.

Frontline Support Members

Angelika Lorinser (Western Ottawa Community Resource Centre)
Annick Lavoie (Carlington Community Health Centre)
Adriana Oatu (Family Services Ottawa)
Anourath Phommachanh (Chrysalis House)
Ayala Sher (Safe Pet Ottawa)
Bernadette Ingungu (Western Ottawa Community Resource Centre)
Bonnie Stephanson (Somerset West Community Health Centre)
Claudia Van Den Heuvel (Pink Triangle Services)
Cindy Onwuachi (Children’s Aid Society)

Angelika Lorinser (Western Ottawa Community Resource Centre)
Annick Lavoie (Carlington Community Health Centre)
Adriana Oatu (Family Services Ottawa)
Anourath Phommachanh (Chrysalis House)
Ayala Sher (Safe Pet Ottawa)
Bernadette Ingungu (Western Ottawa Community Resource Centre)
Bonnie Stephanson (Somerset West Community Health Centre)
Claudia Van Den Heuvel (Pink Triangle Services)
Cindy Onwuachi (Children's Aid Society)
Dani Gaucher (Western Ottawa Community Resource Centre)
Deborah Conners (Carleton University)
Dillon Black (Ottawa Coalition to End Violence Against Women)
Elisaar Jalal (City of Ottawa)
Elke Keating (Family Services Ottawa)
Esther Cesaire (Family Services Ottawa)
Erin Leigh (Ottawa Coalition to End Violence Against Women)
Gabrielle Pelletier (CALACS)
Giovanna Buda (Elizabeth Fry Society)
Gundel Lake (Amethyst Womne's Addiction Centre)
Haney Logan (Community Member)
Helene Boucher (Western Ottawa Community Resource Centre)
Hillary Greer (Carlington Community Health Centre)
Honora Harvey (Interval House)
Iman Ibrahim (Muslim Community Centre)
Indu Gambhir (Indo-Canadian Community Centre)
Jamie Paradis (Children's Aid Society)
Jennifer Trankalis (Bethany Hope)
Josephine Basudde (Ottawa Rape Crisis Centre)
Kathryn McKinley
Kealey Dunlop (Cornerstone)
Kristine Pearce (Children Aid Society)
Linda Merali (Family Services Ottawa)
Lynn Urqhart (New Directions-Catholic Family Services)
Lynne Oreck-Wener (Community Member)
Mariana Migliorini (Public Health Ottawa)
Marie-Louise Boudreau (Catholic Family Services)
Marie Renée Bernagene (Catholic Family Services)
Mary Tersigni-Paltrinieri (Dress for Success)
Marie-Tharese Savage (Eastern Ottawa Resource Centre)
Martine Romulus (Eastern Ottawa Resource Center)
Maureen Parker (Family Services Ottawa)
Melissa Heimerl (Ottawa Victim Services)
Monica Tymofievich (Family Services Ottawa)

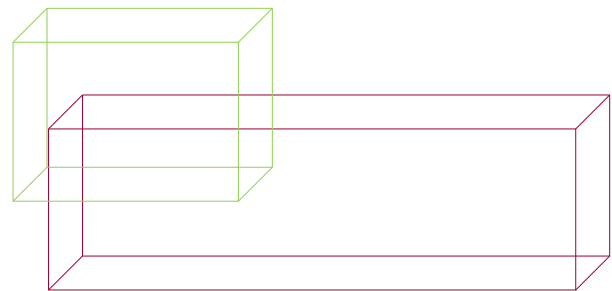

Michele Evans (Children's Aid Society)
Mignon Mildenberger (Community Member)
Melisa Heimerl (Ottawa Victim Services)
Nancy Isaac (Victim Crisis Unit-Ottawa Police Services)
Pauline Racicot (Military Family Resource Center)
Rene-Claude Vaillancourt (Western Ottawa Community Resource Centre)
Roberta Goldmaker (Dress for Success)
Sandy Milne (Family Services Ottawa)
Sadho Alibande (Immigrant Women Services Ottawa)
Sarah Alderwick (Community Member)
Sarah Caspi (Jewish Family Services)
Shahnaz Perveen- Immigrant Women Services Ottawa)
Shar Chowdhury (Family Services Ottawa-Minwaaashin Lodge)
Stefanie Lomataski (Sexual Assault Network)
Tara Leach (Sexual Assault and Partner Abuse Care Program – Ottawa Hospital-Civic Campus)
Tan Bokhari (Elizabeth Fry Society)
Theresa Willoughby (Family Services Ottawa)
Ureda Sylvestre (Western Ottawa Community Resource Centre)
Valerie Bah (Community Member)
Valerie AugeroVoyer (Eastern Ottawa Community Resource Centre)
Violeta Arroyo (Immigrant Women Services of Ottawa)
Vivian Chan-Brouillette (Immigrant Women Services Ottawa)
Vivienne Filitreault (Western Ottawa Community Resource Center)
Zahra Alam (Nelson House)

Public Engagement & Advocacy

2016 was another great year for the Public Engagement Committee. The Committee continues to support the Women's Events Network, which organizes key VAW events throughout the year including Take Back the Night, December 6th Vigil and the Clothesline Project. We also support the annual International Women's Day event with other local, national and international organizations at the Library and Archives. We also continue to support initiatives that draw attention to urgent issues in the community including:

- supporting City for All Women's Initiative anti-Islamophobia event in February, where Erin spoke of its intersections with violence against women, following a rise in attacks against women in hijab in Ottawa;
- participating in an Ottawa U legal panel discussion on the Ghomeshi verdict, where Erin spoke about the important work that front line services provide to survivors of sexual every day, and the impact of the case on these organizations;
- raising awareness of the funding constraints faced by rape crisis and sexual assault support centres as part of Sexual Assault Awareness month in May;
- co-organizing a conference on Rape Culture in June with the Sexual Assault Network (SAN) drawing a crowd of 75 participants.
- during the summer supporting SAN's Project Soundcheck, as project partner, including with participation from MANifest Change facilitators who provide facilitation support to music festival volunteer training.
- Partnering with local LGBTQ organizations for a panel on intimate partner violence in LGBTQ relationships in July.
- Engaging on social media around key calendar celebrations to raise awareness of VAW and gender-based violence, including New Year's Eve; Valentine's Day, St. Patrick's Day; Canada Day; Frosh Week; Halloween and December 6th.

We also continued to organize our annual campaign to raise awareness of intimate partner violence against women: Shine the Light on Woman Abuse. This campaign was started in London, ON by the London Abused Women's Centre. In Ottawa, 2016 had the highest participation thus far, including several community events hosted by participants. We covered three Ottawa neighbourhoods this year: Elgin St, Montreal Rd. and Hintonburg.

In partnership with Shine the Light (STL) outlets across Ontario, we also held a #WearPurple day on November 15th, seeing a great amount of traction on social media. We look forward to expanding this project even more, next year. Thanks to STL committee, chaired by Genevieve Charest, with members leading the way on organizing this year's events including Sonia Legault, Tyler Blanchett and Sarah Jones chaired by Genevieve Charest.

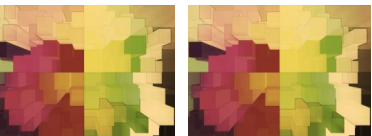

Public Engagement & Advocacy Members

Bailey Reid –Chair of Public Engagement;
Valerie Coliicott – Chair of Advocacy; Women’s Initiatives
for Safer Environments
Adrian Richardson- OC Transpo
Ann McGowan- Community Member
Brittany Basten- Carleton University Campus Safety
Caroline Brunette- Fem’aide
Carrolyn Johnston-Carleton University Equity Services
Catherine McNabb- Planned Parenthood Ottawa
Ariane Wiley – Planned Parenthood Ottawa
Dillon Black- OCTEVAW Cyberviolence Project
Erin Flemming- In Love and In Danger
Geneviève Charest- Community Member
Heather Hazlett- Interval House of Ottawa
Jenna Easton- Community Member
Julie-Jeanne D'Arc Latrémouille- Comité réseau d'Ottawa
Kathryn McKinley-Community Member
Khoa Hoang- Community Member, OPS
Lindsay MacIsaac- Hopewell
Marie-Louise Doyle- OCTEVAW Board
Mark Hargreaves- Carleton University Campus Safety
Matthew Schaaf- OCTEVAW I Can MANifest Change
Shari Canning- Rae of Light Haven
Stefanie Lomatski- Sexual Assault Network
Tara Henderson- Ottawa Rape Crisis Centre
Sarah Jones – Community Member

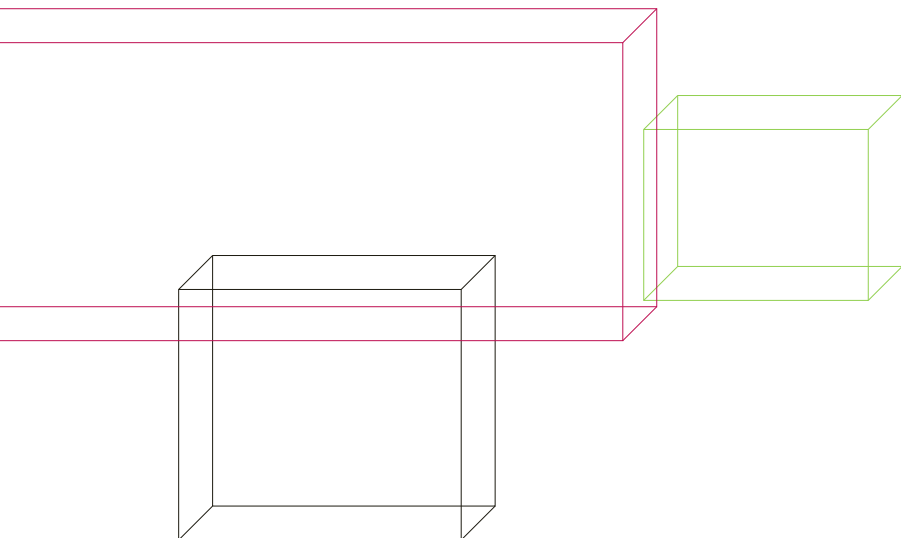

Justice Committee

The Justice Committee continues to identify issues of particular concern for members to address through greater information, awareness and advocacy.

The Justice Committee contributed significant time and energy to support the development of the Mandatory Charging Project's literature review and subsequent survey for survivors, front-line advocates and police. This project is being led by OCTEVAW members Deborah Conners and Prof Holly Johnson at Ottawa University, with financial support from MITACS. This project is about looking at the impacts of mandatory charging policy on women survivors across Ontario. The Justice committee:

- helped gauge whether themes of the literature review were echoed in the community;
- provided concrete feedback on issues to be addressed in the survey, to ensure the complexity and nuanced lived realities of women were reflected in the survey; and
- supported developing survey language that is accessible and meaningful to survivors.

The survey was launched in December 2016, and results will be available in summer 2017.

The Committee and its members are also providing significant time and energy to support the Ottawa Police Service VAW Advisory Committee. Areas of action have been focused on improving response through the VAW Advocate Case Review model; analyzing statistical data and how it captures the local context and response; among others.

The Committee also paid close attention to violence against Indigenous women, with a presentation from Irene at Minwaashin Lodge and from the coordinators of the Sex Trade Outreach Mobile (STORM) Team from Minwaashin Lodge.

Finally, the Committee celebrated advocacy success, with the introduction of new legislation on changing the requirements for a survivor of domestic or sexual violence to leave her lease after 28 days, instead of 2 months. This change in legislation was championed by the Provincial Minister of the Attorney General, the Hon MPP Yasir Naqvi, and OCTEVAW has been supporting this change for many years.

Justice Members

Melissa Heimerl (Ottawa Victim Services)
Tracy Bray (Western Ottawa Community Resource Centre)
Toby Brooks (Community Member)
Natalie Cooper (Children's Aid Society – VAW Team)
Nisse Bourne (Pinecrest Queensway Community Health Centre)
Diane George (The HURT Association)
Dave Fagan (Probation and Parole)
Jessica Poloz (Eastern Ottawa Resource Centre)
Aline Gahimbare (Eastern Ottawa Resource Centre)
Jamie Dunlop (Ottawa Police Service – Criminal Investigations Directorate)
John Ferguson (Ottawa Police Service – Partner Assault Unit)
Joan Gullen (Community Member)
Tia Harza (Legal Aid Clinic – University of Ottawa)
Mark Holmes (New Directions - CFS)
Heidi Illingworth (Canadian Resource Centre for Victims of Crime)
Holly Johnson (University of Ottawa)
Peter Jupp - Chair (Community Member)
Noha Kirkish (Victim Witness Assistance Program)
Jamie Liew (Community Member)
Sunny Marriner (Ottawa Rape Crisis Centre)
Charlene Maurice (Interval House)
Angela McDade (Ottawa Police Service - Sexual Assault and Child Abuse Unit)
Lynne Oreck-Wener (Community Member)
Sandy Pinhey (Western Ottawa Resource Centre)
Darlene Scantland (Victim Witness Assistance Program)
Halina Siedlikowski (Community Member)
Vivian Lee Stewart (Assistant Crown Attorney)
Louise Toone (Legal Aid Clinic - University of Ottawa)
Megan Wallace (Safe Pet Ottawa)
Donna Watson-Elliott (Ottawa Police Service – Victim Crisis Unit)
Annette Werk (Community Member)
Andree-Anne Martel (Ottawa Legal Information Clinic)
Tara Leach (Ottawa Hospital)
Sonia Legault (Community Member)
Stefanie Lomatski (Sexual Assault Network)
Kathryn McKinley (Community Member)
Sandy Milne (FSO)
Laure Prevost (OCTEVAW)
Ayala Sher (SafePet)
Kayla Sanger (SafePet)
Heather Walsh (Nelson House)
Joely Smith (City of Ottawa)

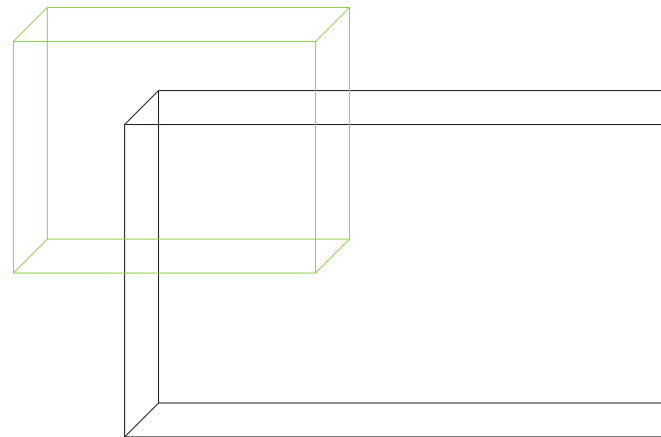
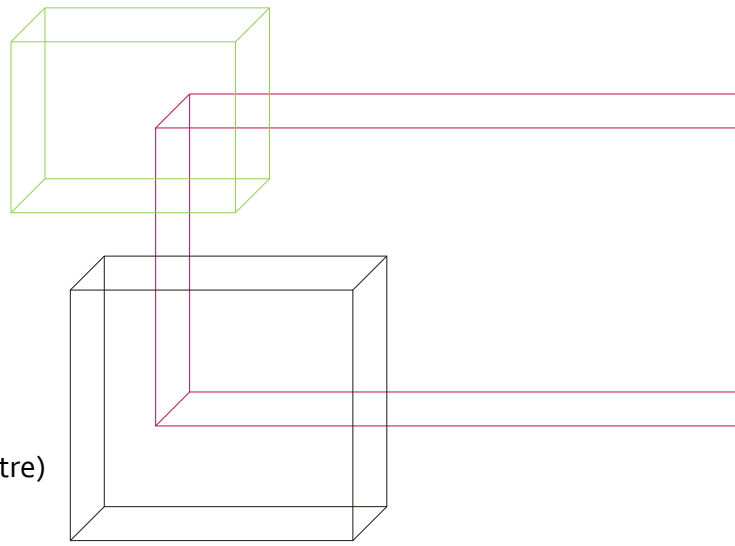



SOCIAL MEDIA.

2016 was a dynamite year for OCTEVAW in terms of connecting online as we continue to grow! We are active on Facebook, Twitter and our website!

Our digital projects!

- R.I.S.E. a bilingual mobile app to help prevent sexual violence on campus! Available for free on iOS and Android
- Just Got Weird, aimed to help students prevent violence on their campuses
- Manifest Change (#MANifestChange) is still continuing to do great work on with their microsite and social media campaign.
- The Media Hub, a project designed to allow media access to information, statistics and sources for reporting on violence against women gained incredible traction and momentum by leveraging it as a provincial resource with the Building a Bigger Wave provincial network of VAW coordinating committees
- Tech Without Violence- this new online hub provides practical information for young social media users and key recommendations social media platforms can use to address and prevent cyberviolence!
- Use The Right Words: Reporting on Sexual Violence Awards were organized by femifesto, OCTEVAW, Ontario Coalition of Rape Crisis Centres, and Office of Sexual Violence Support and Education at Ryerson University hosted by Twitter Canada!

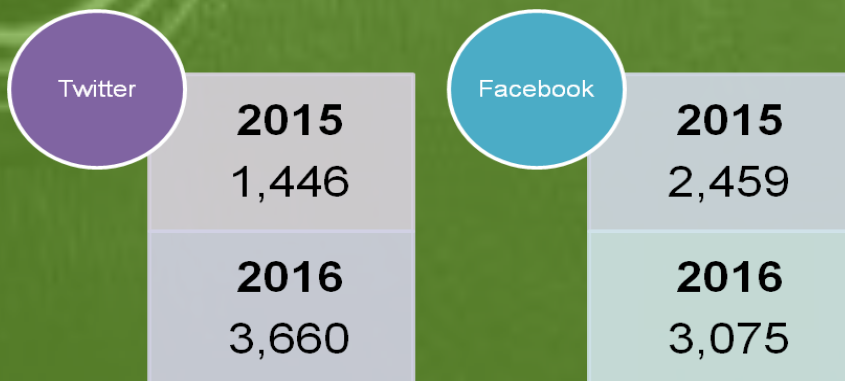

Organic Reach: 39.9K
 Top Tweet Impressions: 89.6 K

OCTEVAW FINANCIAL REPORT

INDEPENDENT AUDITORS' REPORT

To the Board of Directors,

Ottawa Coalition to End Violence Against Women:

We have audited the accompanying financial statements of Ottawa Coalition to End Violence Against Women, which comprise the statement of financial position as at December 31, 2016, and the statements of changes in net assets, operations and cash flows for the year then ended, and a summary of significant accounting policies and other explanatory information.

Management's responsibility for the financial statements

Management is responsible for the preparation and fair presentation of these financial statements in accordance with Canadian accounting standards for not-for-profit organizations, and for such internal control as management determines is necessary to enable the preparation of financial statements that are free from material misstatement, whether due to fraud or error.

Auditors' responsibility

Our responsibility is to express an opinion on these financial statements based on our audit. We conducted our audit in accordance with Canadian generally accepted auditing standards. Those standards require that we comply with ethical requirements and plan and perform the audit to obtain reasonable assurance about whether the financial statements are free from material misstatement.

An audit involves performing procedures to obtain audit evidence about the amounts and disclosures in the financial statements. The procedures selected depend on the auditor's judgment, including the assessment of the risks of material misstatement of the financial statements, whether due to fraud or error. In making those risk assessments, the auditor considers internal control relevant to the entity's preparation and fair presentation of the financial statements in order to design audit procedures that are appropriate in the circumstances, but not for the purpose of expressing an opinion on the effectiveness of the entity's internal control. An audit also includes evaluating the appropriateness of accounting policies used and the reasonableness of accounting estimates made by management, as well as evaluating the overall presentation of the financial statements.

We believe that the audit evidence we have obtained is sufficient and appropriate to provide a basis for our audit opinion.

Opinion

In our opinion, the financial statements present fairly, in all material respects, the financial position of Ottawa Coalition to End Violence Against Women as at December 31, 2016, and the results of its operations and its cash flows for the year then ended in accordance with Canadian accounting standards for not-for-profit organizations.

Ottawa, Ontario
April 3, 2017

OHCD LLP.
OUSELEY HANVEY CLIPSHAM DEEP LLP
Licensed Public Accountants

PAGE 21

STATEMENT OF FINANCIAL POSITION		
	2016	2015
CURRENT ASSETS		
Cash	\$132,792	\$63,307
Accounts receivable	\$4,508	\$4,550
Prepaid expenses	\$6,979	\$2,362
	\$139,463	\$70,218
CURRENT LIABILITIES		
Accounts payable	\$8,287	\$8,679
Deferred revenue	\$90,266	\$9,538
	\$98,553	\$18,217
Internally restricted net assets	\$41,902	\$41,902
Unrestricted net assets	\$3,824	\$10,100
	\$45,726	\$52,002
	\$144,279	\$70,219

		2015
INTERNALLY RESTRICTED NET ASSETS		
Balance beginning and end of the year	\$41,902	\$41,902
UNRESTRICTED NET ASSETS		
Balance - Beginning of year	\$10,100	\$11,588
Net revenue (expenditure) for the year	(\$6,276)	(\$1,488)
Balance end of the year	\$3,824	\$10,100

STATEMENT OF OPERATIONS		
	2016	2015
REVENUE		
City of Ottawa	\$81,727	\$80,519
MCSS	\$31,191	\$22,862
Crime Prevention Ottawa	\$6,057	\$14,790
Minister for Status of Women	\$73,505	\$93,464
Community Foundation of Ottawa	-	\$9,497
Building a Bigger Wave - Mandatory Charging Project Crowd Funding	\$10,461	-
MANifest Change Community Fundraising	\$10,666	-
Memberships	\$1,400	\$1,840
Other revenue	\$3,084	\$7,447
	\$217,491	\$230,419
EXPENDITURE		
Salaries and benefits	\$135,418	\$147,612
Occupancy costs	\$8,162	\$8,921
Staff development	\$700	\$468
Travel	\$1,823	\$679
Outreach	\$5,056	\$3,086
Telephone	\$4,812	\$5,205
Translation	\$6,851	\$3,372
Professional fees	\$46,940	\$28,068
Administration	\$1,509	\$3,227
Supplies	\$1,402	\$4,650
Other expenses	\$6,532	\$20,708
Honorarium	\$1,708	\$1,897
Insurance	\$2,326	\$2,677
Website	\$888	\$1,337
	\$223,767	\$231,907
NET REVENUE (EXPENDITURE) FOR THE YEAR	(\$6,276)	(\$1,488)